

25 Years of Manufacturing Excellence

**zeta**<sup>®</sup>  
**ALARM SYSTEMS**

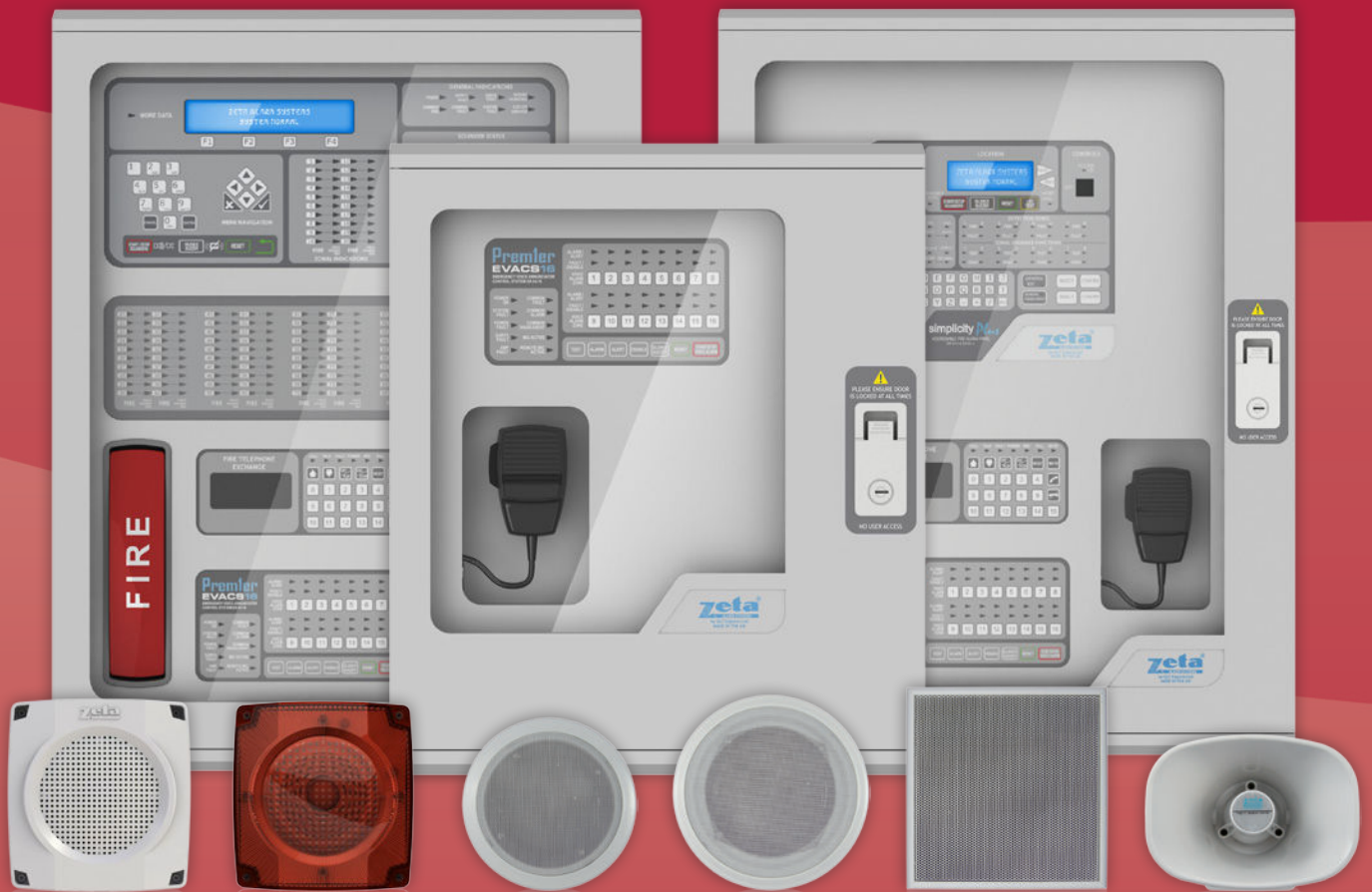

# Premier EVACS 1-16 Voice Alarm System



Assessed to ISO 9001: 2008  
Certificate number 330

# Introduction

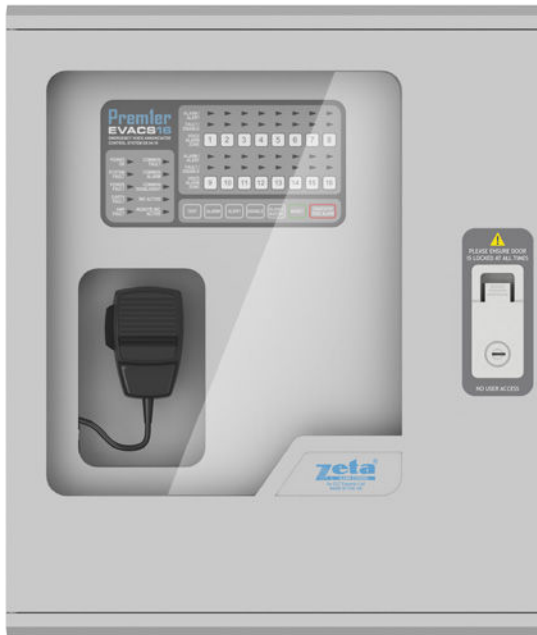

Studies have consistently shown that people respond more readily and with **less panic** in a fire condition (and other emergency situations) when spoken instructions are used rather than loud electric sounders or bells.

The Premier EVACS 1-16 **Voice Evacuation** Control Panel has been designed and developed as a stand alone system that will compliment any Zeta Fire Detection System.

The control panel is a modular design, allowing **up to 16 channels**, units to be networked via RS485.

Each unit has **80 watts** output divided to 2 sub-channels. Also 2 x 24Vdc is provided to drive alarm when needed.

The Premier EVACS 1-16 **Configuration Software** lets you easily customise and programme a huge range of the panel's features including; volume control, trigger matrix, microphone configuration, recording/ downloading bespoke alert and evacuate messages.

Model	EVACS1-16
Part No.	180-105
No. of Channels	Twin Channels
Output/Channel	40 Watts
Total Watts	80 Watts
Evacuate Trigger Input	1 common evacuate input
Alert Trigger Input	1 common alert input
Messages	2 x 55 second duration (1 evacuate message, 1 alert message) recorded via PC
Interface to MKII Protocol	1 input available
Alarm Output	2 x 500mA - 24Vdc, designed to trigger visual alarm
Speaker Voltage	70-100V Line
Mains Voltage	230V± 10% - 15%, 50/60Hz
Power Supply	2.0 Amp Integral Power Supply
Max. Battery Back-up	2 x 17.0 AH - 12V SLA
Dimensions (h x w x d)	475.5 x 400 x 178mm
Weight	7.1kg
Network	Up to 16 EVACS units can be networked over 1000 metres
Total Network Capacity	1280 Watts

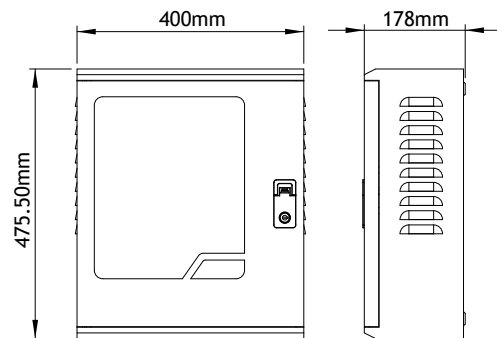

## Product Features

- ✓ System can be networked up to 16 x twin channels totalling 1280w
- ✓ Total live broadcasting from any handheld microphone on the network
- ✓ Full option to isolate or select any live broadcasting from any of the 16 units on the network
- ✓ Complies with EN54 part 16
- ✓ Alert message up to 55 second
- ✓ Evacuate message up to 1 minute
- ✓ CE marked
- ✓ Messages are transferred to the system via a PC
- ✓ 40W per channel
- ✓ Can play evacuate to selected channel(s) & alert to all others
- ✓ All speakers have selectable power output
- ✓ Choice of speakers and combined speaker and LED flashers available

# System Description

## As a Single Panel

The EVACS 1-16 is designed to meet the full standard requirements of EN54 part 16. Each panel is equipped with the following:

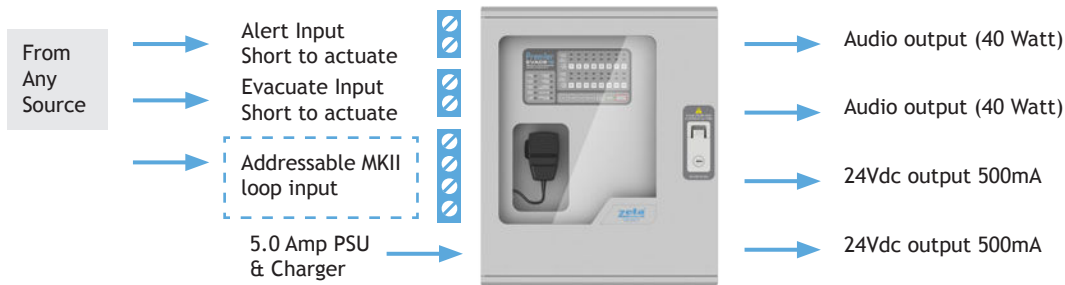

## As a Multi-Panel

Should more output wattage be required a multiple of EVACS 1-16 can be linked via a twisted pair cable and the system will be configured as follows:

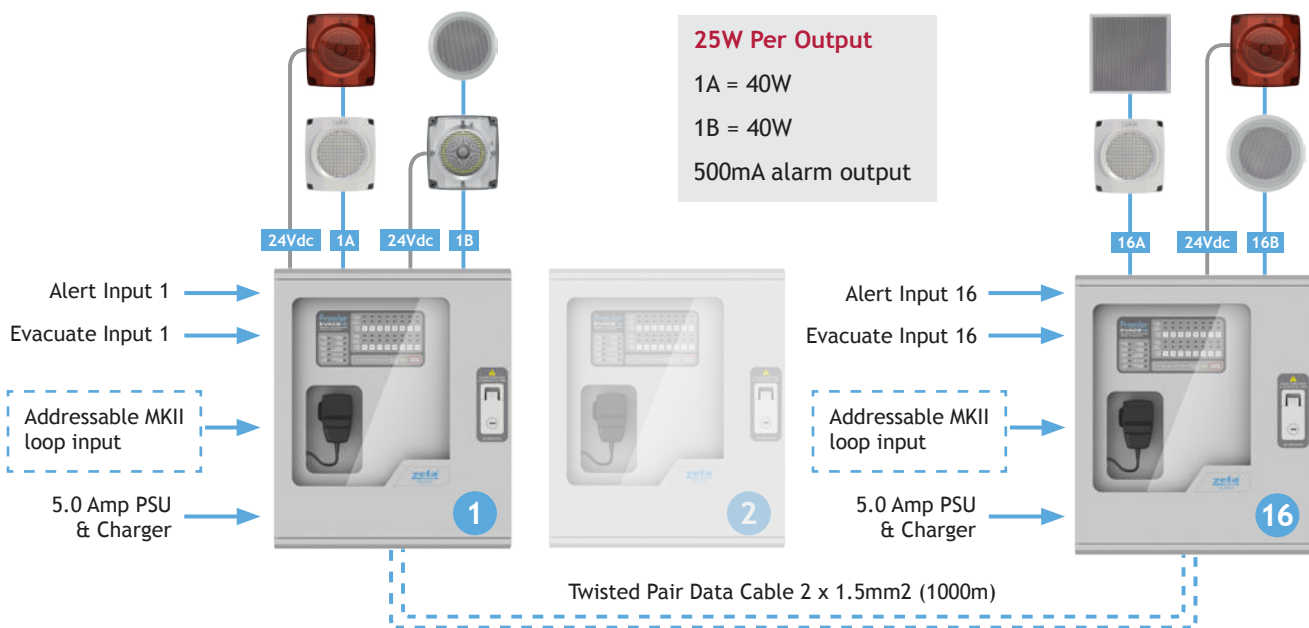

### Config 1

- Each Alert & Evac input will trigger Alert & Evac messages for that panel only.
- Any live broadcasting from any panel can be selected to broadcast locally or access the network to all outputs.

### Config 2

Using the PC Configuration Software EVP-MKII each panel output can be activated using a triggering matrix for any or all the panels.

## Addressable Interface for Networked System

Any system with 1 or more panels networked can be interfaced to a MKII loop and each panel will be seen at the fire panel as a sounder circuit controller. All Alert/ Evacuate outputs of each and all the panels will be controlled from the cause & effect programming of the fire control panel. That will leave the live broadcasting to be operated normally from any of the networked EVACS 1-16 panels.

# Configuration Software

## Title Screen

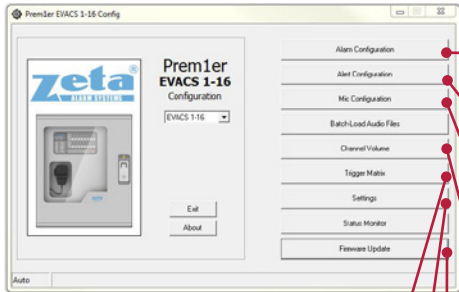

## Evacuate Message

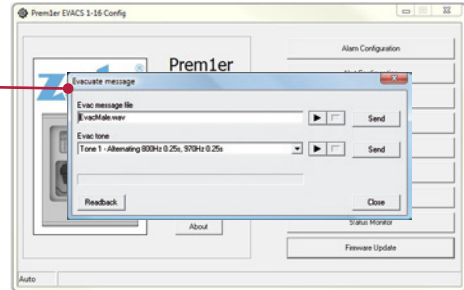

Select evacuate message

## Trigger Matrix

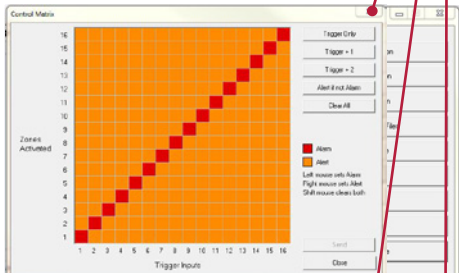

Choose which message should be played on each channel

## Alert Message

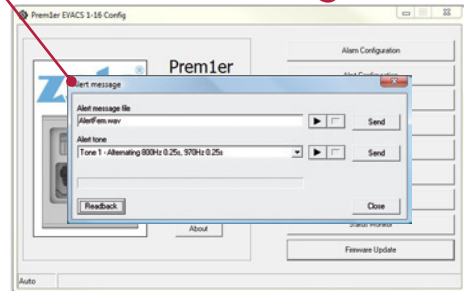

Select alert message

## Settings

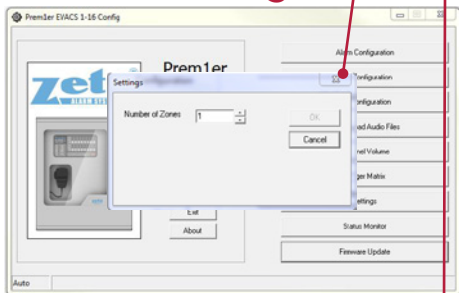

## Microphone Tone

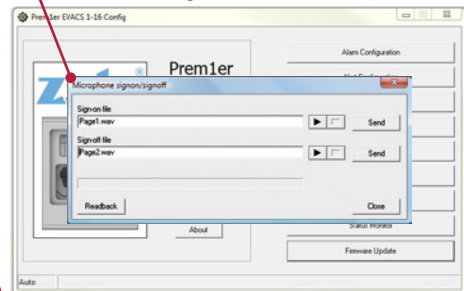

Select the sign-on and sign-off tones

## Status Monitor

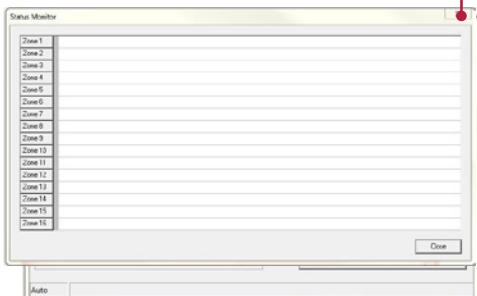

## Channel Volume

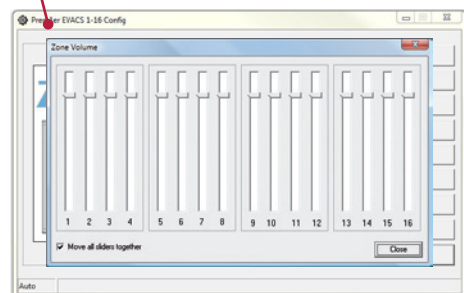

Move sliders to adjust speaker volume

# Speakers



Z-CS5/EN

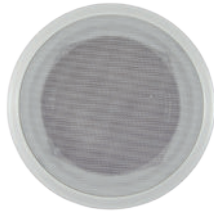

Z-CS6/EN

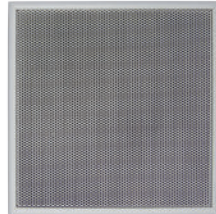

ZT-08W



ZT-67Q



ZT-SF/W



ZT-SSF/R

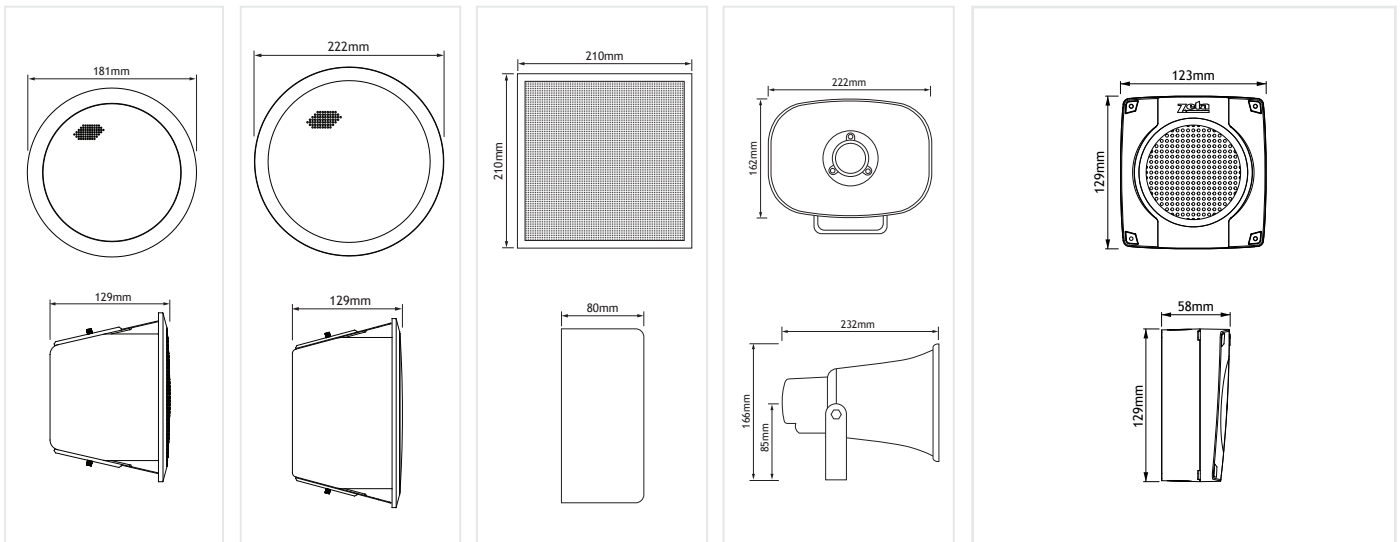

Model	Z-CS5/EN	Z-CS6/EN	ZT-08W	ZT-67Q	ZT-SF/W	ZT-SF/R	ZT-SSF/R	ZT-SSF/C
Part No.	180-110A	180-111A	180-112A	180-113A	180-120	180-121	180-122	180-123
Rated Power	6W / 3W / 1.5W / 0.75W	6W / 3W / 1.5W / 0.75W	3W / 1.5W / 0.75W	15W	0.33/0.5W			
Input Impedance	100V 1.7kΩ (6W) 3.3kΩ (3W) 6.7kΩ (1.5W) 13kΩ (0.75W)	100V 1.7kΩ (6W) 3.3kΩ (3W) 6.7kΩ (1.5W) 13kΩ (0.75W)	100V 3.33kΩ (3W) 6.66kΩ (1.5W) 13.33kΩ (0.75W)	100V 0.66kΩ (15W)	100V 20kΩ (0.5W) 30kΩ (0.33W)			
Input Voltage	100V	100V	100V	100V	100V			
Frequency Response	180Hz ~ 20KHz	170Hz ~ 20KHz	120Hz ~ 15KHz	250Hz ~ 7KHz	120-15KHz			
Maximum SPL	91dB	91dB	90dB	106dB (+/- 2dB)	85dB (+/- 2dB)			
Flasher	N/A	N/A	N/A	N/A	N/A	N/A	Red	White
Dimensions	ø181 x 129mm	ø222 x 129mm	210 x 210 x 80mm	222 x 232 x 166mm	123 x 129 x 58mm			
Weight	1.29kg	1.57kg	1.93kg	1.54kg	480g			



# Other Zeta Products

25 Years of Manufacturing Excellence



**Simplicity Plus**  
Addressable Fire  
Alarm System



LPCB

25 Years of Manufacturing Excellence



**Premier M Plus & Infinity 8**  
Conventional Fire  
Alarm Systems



LPCB

25 Years of Manufacturing Excellence



**INFINITY *id2***  
The 2 Wire Fire Detection  
System for Professionals



LPCB

25 Years of Manufacturing Excellence



**Premier Quatro**  
Addressable Fire  
Alarm System



LPCB

25 Years of Manufacturing Excellence



**Premier EX Pro**  
Combined Fire & Extinguishing  
Control Panel



LPCB

**Gas Sense**  
Gas Detection System



**zeta**  
ALARM SYSTEMS

Available now from:

