



# Operation Manual

Table of contents
-------------------

General Information.....	3
Safety Warning.....	3
Symbols.....	3
Important Information.....	4
Limitation of liability.....	4
Warranty.....	4
Technical Specification.....	5
General description.....	5
Measuring method.....	5
Front View.....	6
Inside View.....	6
Installation and Wiring.....	7
Mounting the Sensor.....	7
Mechanical Mounting.....	7
Electrical Connection.....	7
Analogue gas detector GS-220.BC.V.ZETA.....	8
Operating Instructions.....	8
Initial stabilisation.....	8
Working mode.....	8
Alarm 1.....	8
Alarm 2.....	8
Alarm 3.....	8
Fault.....	8
Sensor calibration.....	9
Maintenance & servicing.....	10
Cleaning.....	10
Servicing.....	10
Servicing frequency.....	10
Ordering codes.....	11

## General Information

This manual is designed to provide users with simple and precise information. Manufacturer shall not be held responsible or liable for any misinterpretation that may result from the reading of this manual. Although every effort is made to ensure accuracy, this manual may contain unintentional technical inaccuracies.

Please read the following notice carefully before installation and start-up, paying particular attention to the end – user safety instructions. This user's guide should be distributed to every individual involved in the start-up, use, maintenance or repair of the product. The information contained in this manual, the data and technical drawings are correct as of the data of publication. For additional information, please contact Zeta Alarms Ltd.

Manufacturer reserves the right to modify the technical characteristics of its equipment without notice to improve product performance.

## Safety Warnings



Installation and electric connections should be performed by a qualified professional, according to Manufacturer's specifications and to the standards of authorities in the field. Failure to observe these rules may result in serious injury. Accuracy, particularly regarding electricity and assembly (coupling, network connections) is imperative.

Icons have been placed on the sensor to call attention to general use safety precautions. These labels are an integral component of the sensor. The meanings of these labels are described below

## Symbols



Please refer to the instructions



**Caution:** In the current operating mode, failure to adhere to the instructions preceding this symbol can result in a risk of electric shock or death.



**This equipment must be grounded**



**Safety grounding terminal.** A cable of adequate diameter must ground any terminal with this signal.



The accordance with directive

### **Important Information**

Gas detectors must be checked for correct functioning by a qualified person after the installation but before putting into operation. The was checked for correct functioning prior to delivery. The calibration was performed with suitable calibration gases. This does not release the user from the obligation to perform a check with test gas when the transmitter is put into operation after the installation and before putting into operation.

### **Limitations of Liability**

Neither Zeta Alarms Ltd nor any other affiliated organization shall be held liable under any circumstances for any damage whatsoever including, without limitations, damages for loss of production, interruption of production, loss of information, controller failure, personal injury, loss of time, money, or materials, or the inability to use the product, even in the event that Zeta Alarms Ltd had been informed of such damages.

### **Warranty**

We hereby guarantee that the gas detectors GS-220.BC.V.ZETA have been manufactured and tested to the highest quality standards.

We warrant above products to be free from materials and work defects for the period of 24 months from the date of purchase. If such defects appear during the warranty period products will be repaired or replaced with new products without charge.

## Technical specifications

### General description:

A stationary gas detection system consists of a detector (transmitter) and a central controller. The detector and the controller are connected with a cable. The detector converts the gas concentration into an electric measurement signal and transmits it via the cable for processing to the controller.

Gas detectors GS-220.BC.V.ZETA are intended for detection of explosive and toxic gases. They are suitable for detection of different gases depending on the gas detection element.

### Measuring method:

The following measuring methods are used:

1. Catalytic sensors for measurement of explosive gases.
2. Electrochemical sensors for toxic gases.
3. Infrared sensors for CO<sub>2</sub>.
4. Semiconductor sensors for refrigerant gases.

**Table. 1**

<b>DETECTED GASES</b>	See Table. Ordering codes
Gas feed	<b>Diffusion</b>
<b>POWER SUPPLY</b>	
Working voltage	12 – 30 VDC
Power Consumption	3W
<b>OUTPUT SIGNAL</b>	
GS-220.BC.V.ZETA	4 – 20mA
<b>ENVIRONMENTLE CONDITIONS</b>	
Working temperature	-20 - + 50°C
Humidity range	10 – 90% R.H.
Atmospheric pressure range	800 – 1100 hPa
<b>MECHANICAL</b>	
Dimensions	155 x 120 x 48mm
Weight	0,320kg
Enclosure material	Aluminium
Ingress protection	IP65
Cable connection	Cable gland(s) M16 (M20)
<b>CERTIFICATION</b>	
Conformity mark	CE
ATEX certification	ATEX II 2G Ex d (ib) ma IIC T4 Gb
	ATEX II 2D Ex tb (ib) ma IIIC T135oC IP65 Db

Front view – gas detector GS-220.BC.V.ZETA

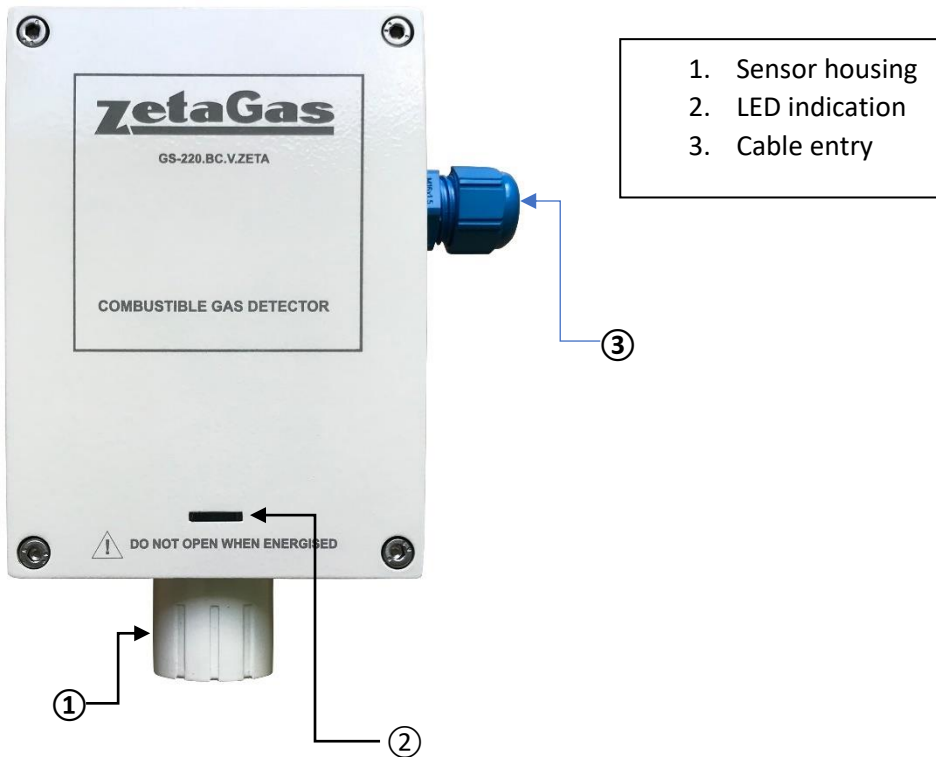

Inside view – gas detector GS-220.BC.V.ZETA

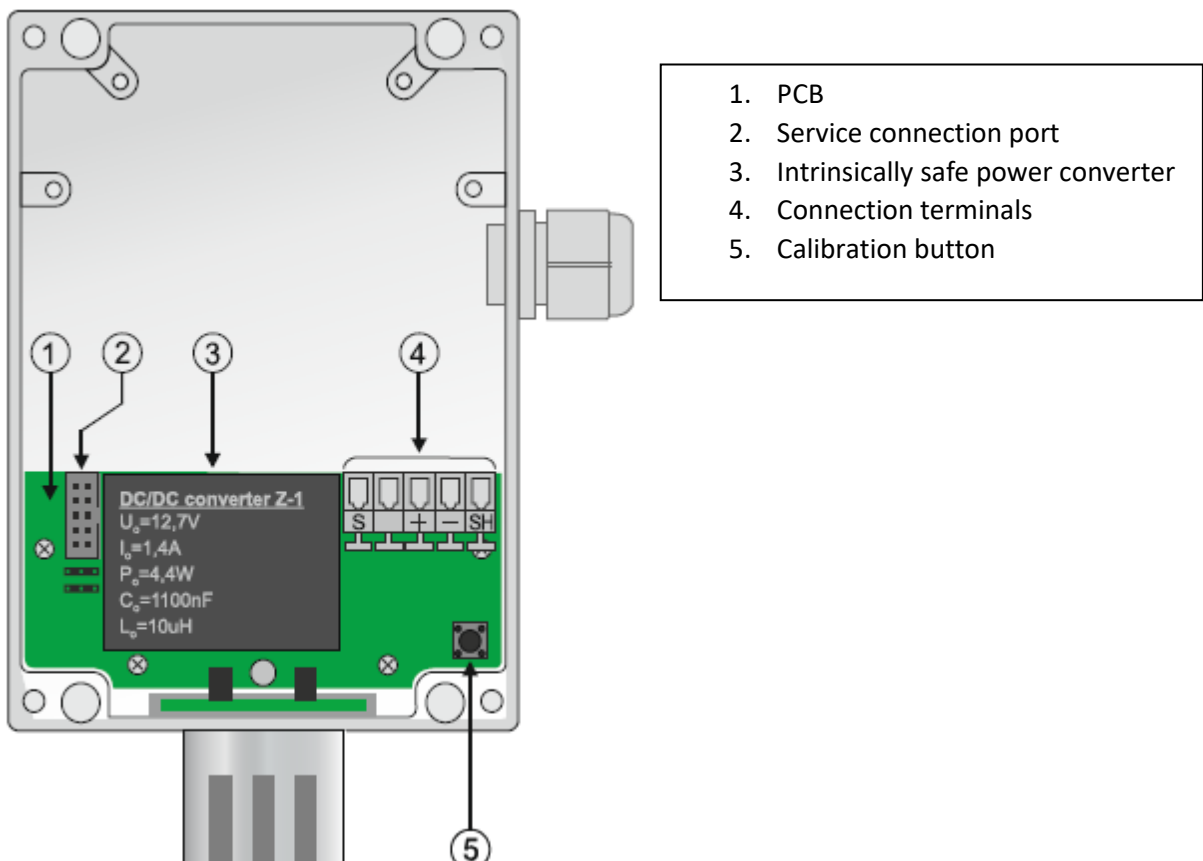

## Installation and wiring

### Mounting the detector

Gas detector for monitoring of flammable gases and leakages of toxic gases should be installed close to potential sources of release. For gases heavier than air below and for gases lighter than air above the source of release. Detectors for monitoring at working places are installed at face / respiration level.

When deciding on the position for the transmitter, make sure that it is always accessible for service and maintenance.

### Mechanical mounting

Gas detector is attached to the wall via 4 mounting screws. Sensor opening to be placed downwards. Drill 4 holes according to the drilling diagram.

### Drilling diagram:

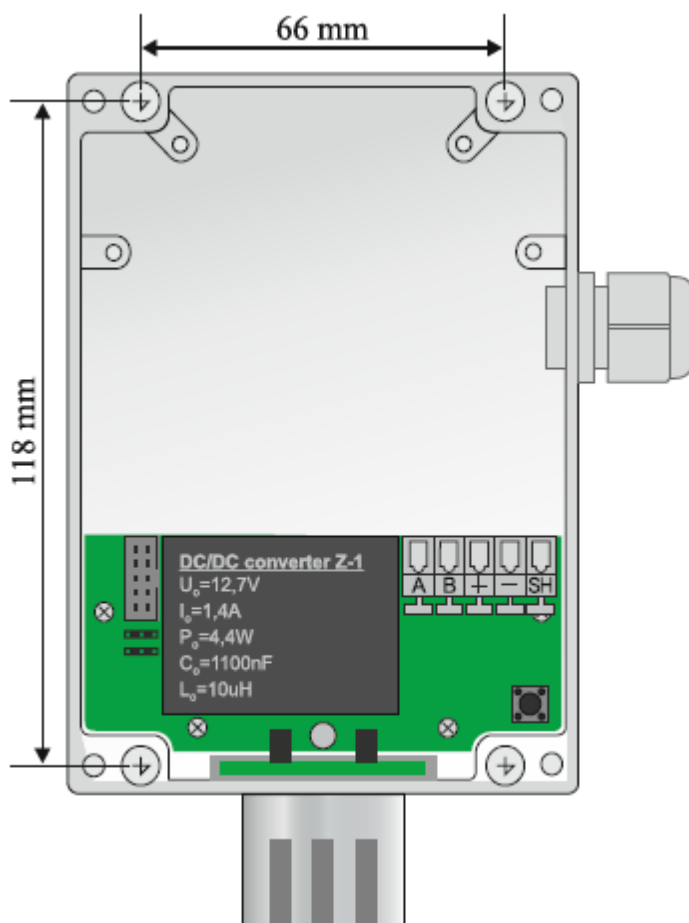

### Electrical connections

The electrical connection must be carried out by a specialist and (with the controller) with the power supply disconnected.

## Connection Diagram GS-220.BC.V.ZETA Analogue Gas Detector 4 – 20mA

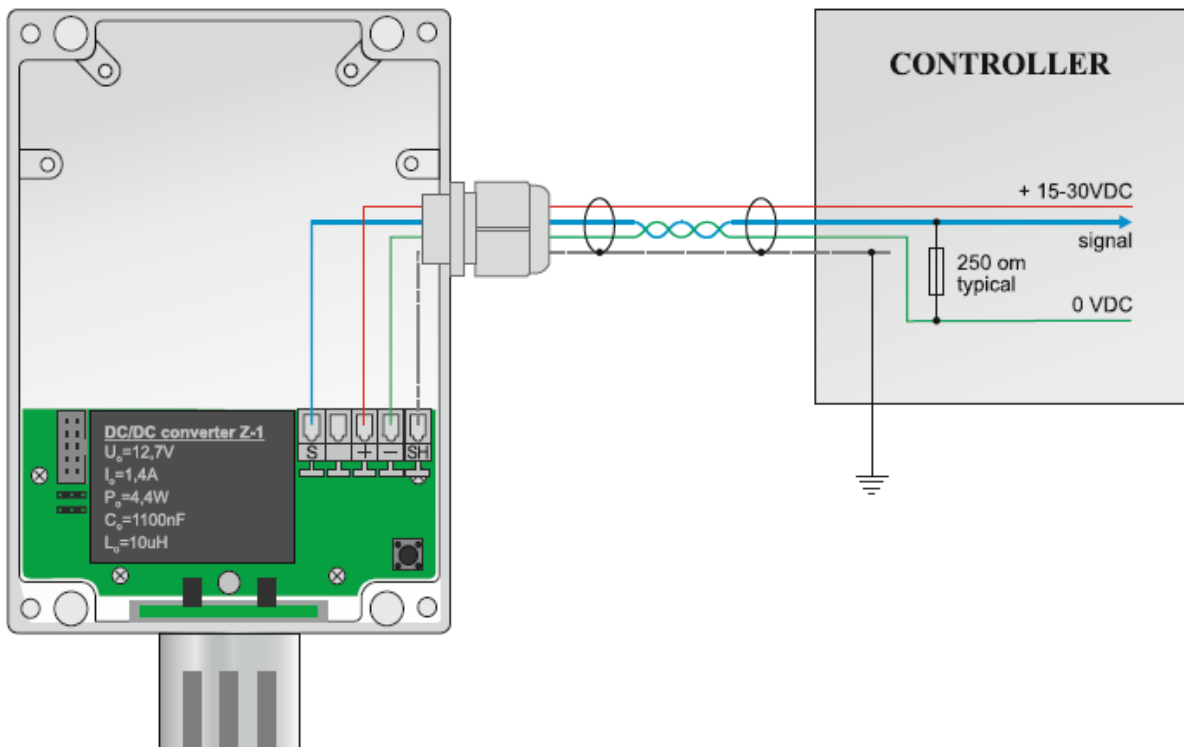

## Operating instructions

### 1. Initial stabilisation

Preheating and initial testing of gas sensing element.

Indication: Green LED is flashing quickly.

### 2. Working mode

In this mode sensor is ready to detect gas concentration.

Indication: Green LED is flashing slowly.

### 3. Alarm 1

First alarm level is reached.

Indication: Red LED is flashing slowly.

### 4. Alarm 2

Second alarm level is reached.

Indication: Red LED is flashing quickly.

### 5. Alarm 3

Third alarm level is reached.

Indication: Red LED lights permanently.

### 6. Fault

Sensor element fault.

Indication: Orange LED is flashing.



## Sensor Calibration

Gas detectors must be calibrated and periodically checked to ensure detectors accuracy and system integrity. It is important to install stationary gas detectors at locations where the calibration can be performed easily. The intervals between calibration can be different from sensor to sensor. However, it is good practice to check the detector during the first 30 days after installation. During this period, it is possible to observe how well the detector is adapting to its new environment. If the detector functions properly for 30 continuous days, this provides a good degree of confidence about the installation. Any possible problems can be identified and corrected during this time. Experience indicates that a detector surviving 30 days after the initial installation will have a good chance of performing its functions for the duration expected. Most problems such as inappropriate detector location, interference from other gases, or the loss of sensitivity will arise during this time. Afterward, a maintenance schedule, including calibration intervals, should be established.

Normally, a 6-monthly calibration period is adequate to ensure the effectiveness and sensibility of each sensor. This check will also afford you the opportunity to maintain the system's accuracy.

### Calibration Procedure

Calibration of the gas detector includes two steps. First the "zero" must be set and then the "span" must be calibrated.

1. To initiate calibration press and hold the tactile button on the PCB or place the magnetic gas calibration cup.
2. After 5sec all LED's will flash.
3. After 2 more seconds the yellow LED will turn OFF, red LED is ON and the green LED is flashing once every second for the period of 30 seconds. In this case you may chose from the following:
  - To calibrate the sensor – continue holding the button and apply zero gas;
  - To refuse calibration on ZERO air – release the button (remove the magnetic cap) – red LED will flash for 2 seconds.
4. Green LED and red LED start to flash alternately. Now you must apply the span gas and again press and hold the button or place the magnetic gas calibration cup. Now the alarm levels are automatically adjusted. Red LED lights and green LED are flashing twice at every 2 seconds for 30 seconds. In this case you may choose from the following:
  - To calibrate the sensor – continue applying span gas for 30 seconds and the red LED will flash for 2 seconds confirming alarm levels settings;
  - To refuse calibration of alarm levels – release the button or remove the magnetic cap and the red LED will flash for 2 seconds.
5. When you complete the above steps, calibration is finished, and all LED's will flash for 5 seconds.

NOTE: If during the calibration you release the button or remove the magnetic cap for more than 4 minutes, calibration will be terminated and the previously saved values for pure air and alarm levels will be recovered.

## Maintenance and servicing

### Cleaning

If necessary, clean the exterior of the enclosure with a damp cloth. Do not use alcohol or ammonia-based liquids to clean the detector.

### Servicing

We recommend the user to periodically inspect the proper triggering of alarm and fault relays, the buzzer and indications on the front panel of the controller. Test must be done by applying etalone gas mixture to the gas detectors.



The adjustment operations of the gas detection system must be done only by authorized, trained personnel because they may compromise gas detection system reliability.

### Servicing frequency

Zeta Alarms Ltd, recommends regular testing of fixed gas detection installations. The type of test consists of injecting a standard gas mixture of sufficient concentration into the detector to set off the preadjusted alarms. This test does not, replace a full calibration of the detector. Frequency of the gas testing depends on the industrial application in which the detectors are used. Inspection should be done frequently the first months after installation starts up, later it may be spaced out if no problem is observed.

If a detector does not react upon contact with gas, it must be calibrated. The frequency of calibration will depend on tests (humidity, temperature, dust, etc.); calibration should occur at least once every year. We also recommend calibrating the detector after exposure to high gas concentrations. The site manager is responsible for implementing the safety procedures on site. Zeta Alarms Ltd is not responsible for implementing safety procedures.

**Ordering codes****Analogue gas detectors GS-220.BC.V.ZETA for combustible gases**

<b>Model – ordering code</b>	<b>Detected gas</b>	<b>Gas concentration</b>
GS-220.BC.V.ZETA.MET.100	METHANE	0 – 100% LEL
GS-220.BC.V.ZETA.PRO.100	PROPANE	0 – 100% LEL
GS-220.BC.V.ZETA.BUT.100	N-BUTANE	0 – 100% LEL
GS-220.BC.V.ZETA.PEN.100	N-PENTANE	0 – 100% LEL
GS-220.BC.V.ZETA.HEX.100	N-HEXTANE	0 – 100% LEL
GS-220.BC.V.ZETA.HEP.100	N-HEPTANE	0 – 100% LEL
GS-220.BC.V.ZETA.OCT.100	N-OCTANE	0 – 100% LEL
GS-220.BC.V.ZETA.MNL.100	METHANOL	0 – 100% LEL
GS-220.BC.V.ZETA.ETL.100	ETHANOL	0 – 100% LEL
GS-220.BC.V.ZETA.PRO.100	ISO-PROPANOL	0 – 100% LEL
GS-220.BC.V.ZETA.ACE.100	ACETONE	0 – 100% LEL
GS-220.BC.V.ZETA.MEK.100	METHYL ETHYL KETONE	0 – 100% LEL
GS-220.BC.V.ZETA.TOL.100	TOLUENE	0 – 100% LEL
GS-220.BC.V.ZETA.EAC.100	ETHYL ACETATE	0 – 100% LEL
GS-220.BC.V.ZETA.HYD.100	HYDROGEN	0 – 100% LEL
GS-220.BC.V.ZETA.AMM.100	AMMONIA	0 – 100% LEL
GS-220.BC.V.ZETA.UPT.100	UNLEADED PETROL	0 – 100% LEL
GS-220.BC.V.ZETA.ETH.100	ETHYLENE	0 – 100% LEL

**Analogue gas detectors GS-220.BC.V.ZETA for toxic gases**

<b>Model – ordering code</b>	<b>Detected gas</b>	<b>Gas concentration</b>
GS-220.BC.V.ZETA.CO.500	CARBON MONOXIDE	0 – 500ppm
GS-220.BC.V.ZETA.NO2.30	NITROGEN DIOXIDE	0 – 30ppm
GS-220.BC.V.ZETA.H2S.100	HYDROGEN SULPHIDE	0 – 100ppm
GS-220.BC.V.ZETA.AMM.100P	AMMONIA	0 – 100ppm
GS-220.BC.V.ZETA.CL2.10	CHLORINE	0 – 10ppm
GS-220.BC.V.ZETA.O2.25	OXYGEN	0 – 25%v

**Analogue gas detectors GS-220.BC.V.ZETA for refrigerant gases**

<b>Model – ordering code</b>	<b>Detected gas</b>	<b>Gas concentration</b>
GS-220.BC.V.ZETA.AMM.2000	AMMONIA	0 – 2000ppm
GS-220.BC.V.ZETA.134A.2000	R-134a	0 – 2000ppm
GS-220.BC.V.ZETA.404A.2000	R-404a	0 – 2000ppm
GS-220.BC.V.ZETA.407C.2000	R-407c	0 – 2000ppm
GS-220.BC.V.ZETA.410A.2000	R-410a	0 – 2000ppm
GS-220.BC.V.ZETA.290.2000	R-290	0 – 2000ppm

