

ZD-CO-9B User Manual



**CARBON MONOXIDE
POISONOUS GAS ALARM**

CONTENTS

INTRODUCTION	2	WHAT TO DO IN THE EVENT OF AN ALARM	14
FEATURES	2	USEFUL NUMBERS	15
CARBON MONOXIDE AND HOW IT CAN AFFECT YOU AND YOUR FAMILY	3	TECHNICAL INFORMATION	16
WHERE TO INSTALL YOUR DETECTOR	5	DISPOSAL	17
HOW TO INSTALL YOUR DETECTOR	7	7 YEAR WARRANTY	18
BATTERY INSTALLATION/REPLACEMENT	8	RETURNS	19
OPERATING FEATURES	9	PRODUCT RANGE	19
UNDERSTANDING THE PRODUCT'S INDICATORS	12	NOTES	20
MAINTAINING / TESTING YOUR DETECTOR	13		

NOTE: This User Manual is also available in large text and other formats. Please call **+44 (0) 1792 455 175** for further information

INTRODUCTION

Congratulations! You've made a wise investment in an innovative product and your personal safety. The ZD-CO-9B Carbon Monoxide Poisonous Gas Alarm is one of a new generation of domestic life safety products from Zeta Alarm Systems, which combines the latest technology and innovative design to provide an aesthetically pleasing and effective contribution to your home safety.

The Zeta range of products is constantly being improved and expanded. Please visit www.zetaalarmsystems.com to find out about the latest additions to our product range.

Zeta Alarm Systems provide some of the most technologically advanced carbon monoxide detectors in the world.

FEATURES

- An advanced electrochemical sensor designed to accurately measure low levels of carbon monoxide (CO) providing an early warning of toxic CO levels in your home
- Detects carbon monoxide continuously
- Resistant to false alarms caused by normal household contaminants
- Sounds a loud 85dB alarm (at 1m/3 feet) to alert you in case of an emergency
- Test/reset button
- Regular self-check to ensure detector is operating correctly
- Simple to mount, portable, ideal for travelling
- Certified to the European Standard for Carbon Monoxide Alarms
BS EN 50291 : 2001
- 7 year warranty

CARBON MONOXIDE AND HOW IT CAN AFFECT YOU AND YOUR FAMILY

Carbon monoxide is a poisonous gas that kills hundreds of people each year and injures many more. It is often referred to as the silent killer, it has no odour or taste and cannot be seen. Like oxygen, CO enters the body through the lungs during the normal breathing process. It competes with oxygen by replacing it in the red blood cells, thereby reducing the flow of oxygen to the heart, brain and other vital organs. In high concentrations, CO can kill in minutes.

Many cases of reported carbon monoxide poisoning indicate that while victims are aware they are not feeling well, they become disorientated and unable to save themselves by either exiting the building or calling for assistance. Exposure during sleep is particularly dangerous because the victim usually does not wake up.

Symptoms of CO poisoning

The following symptoms may be related to CO poisoning which all household members should be made aware of:

- **Mild Exposure:** Slight headache, nausea, vomiting, fatigue (often described as 'flu-like' symptoms)

- **Medium Exposure:** Severe throbbing headache, drowsiness, confusion, fast heart rate
- **Extreme Exposure:** Unconsciousness, convulsions, cardiorespiratory failure, death

Your Zeta CO detector monitors the level of CO as parts per million (ppm) in the atmosphere surrounding the detector.

- 35ppm** The maximum allowable concentration for continuous exposure for healthy adults in any 8 hour period, as recommended by the Occupational Safety and Health Administration (OSHA).
- 200ppm** Slight headache, fatigue, dizziness, nausea after 2 - 3 hours.
- 400ppm** Frontal headaches within 1 - 2 hours, life threatening after 3 hours.
- 800ppm** Dizziness, nausea and convulsions within 45 minutes. Unconsciousness within 2 hours. Death within 2 - 3 hours.

Should you suspect CO may be affecting you or your family, open the doors and windows of your property to ventilate, turn off your appliances and evacuate the premises. At this time the authorities should be contacted

to locate the source of the carbon monoxide before re-entering the building. Medical attention should be sought for anyone suffering the effects of CO poisoning (headache, nausea, see page 3).

Common sources of CO

- Oil and gas boilers
- Portable generators
- Oil or solid fuel cookers
- Gas or paraffin heaters
- Barbecues
- Clogged chimneys
- Gas, wood, coal or coke fireplaces
- Cigarette smoke
- Gas appliances
- Any fossil fuel burning appliance

! **WARNING:** This Zeta carbon monoxide detector is not a combustible gas detector, nor a smoke detector. Please install the proper detectors to detect combustible gases, or smoke.

This CO detector should not be seen as a substitute for the proper installation, use, and maintenance of fuel-burning appliances (including appropriate ventilation and exhaust systems), nor the sweeping of chimneys.

! **WARNING:** Do not use this carbon monoxide detector on an intermittent basis, or as a portable detector for trying to trace one source of the spillage of combustion

products from fuel-burning appliances or from chimneys.

Do not:

- **IGNORE ANY WARNING FROM YOUR CO DETECTOR!**
- Burn charcoal inside your home, caravan, tent or cabin
- Install, convert or service fuel-burning appliances without proper knowledge, skill and expertise
- Use a gas cooker for heating a room
- Operate unvented gas burning appliances using paraffin or natural gas in closed rooms
- Operate petrol-powered engines indoors or in confined areas
- Ignore a safety device when it shuts an appliance off

Always:

- Buy appliances accepted by a recognised testing laboratory
- Install appliances according to the manufacturer's instructions
- Have appliance installations carried out by professionals (for gas appliances engineers should be registered)
- Have your appliances checked regularly by a qualified service engineer
- Have your chimneys and flues cleaned professionally every year

- Make regular visual inspections of all fuel-burning appliances
- Do not barbecue indoors, or in an attached garage
- Open windows when a fireplace or oil/solid fuel cooker is in use
- Only install CO detectors that meet the requirements of BS EN 50291:2001 in your home
- Be aware of CO poisoning symptoms (see page 3)

EDUCATE YOURSELF AND YOUR FAMILY ON THE SOURCES AND SYMPTOMS OF CO POISONING AND HOW TO USE YOUR CARBON MONOXIDE DETECTOR

WHERE TO INSTALL YOUR DETECTOR

! **WARNING:** This detector will only indicate the presence of carbon monoxide gas at the sensor. Carbon monoxide gas may be present in other areas.

In which room should the detector be installed?

Ideally, an apparatus should be installed in every room containing a fuel burning appliance. Additional apparatus may be installed to ensure that adequate warning is given for occupants in other rooms, by locating apparatus in:

- Remote rooms in which the occupant(s) spend considerable time whilst awake and from which they may not be able hear an alarm from apparatus in another part of the premises, and
- Every sleeping room

However, if there is a fuel burning appliance in more than one room and the number of apparatus is limited, the following points should be considered when deciding where best to put the apparatus:

- Locate the apparatus in a room containing a flueless or open-flued appliance, and
- Locate apparatus in a room where the occupant(s) spend most time
- If the domestic premises is a bedsit (a

single room serving as both sitting and bedroom) then the apparatus should be put as far from the cooking appliances as possible but near to where the person sleeps

- If the appliance is in a room not normally used (for example a boiler room), the apparatus should be put just outside the room so that the alarm may be heard more easily.

Where in the room should I place the detector?

Apparatus located in the same room as a fuel-burning appliance:

- a For both wall and ceiling mounted apparatus the following applies:
- The apparatus should be at a horizontal distance of between 1m and 3m from the potential source
 - If there is a partition in a room, the apparatus should be located on the same side of the partition as the potential source
 - Carbon Monoxide detectors in rooms with sloped ceilings should be located at the high side of the room

- b In addition to the previous points the following must be observed:

If the apparatus is located on a wall:

- it should be located close to the ceiling;
- it should be located at a height greater

than the height of any door or window;

- it should be at least 150mm from the ceiling.

If the apparatus is located on the ceiling:

- it should be at least 300mm from any wall and any ceiling obstruction e.g. light fittings.

Apparatus located in sleeping rooms and in rooms remote from a fuel burning appliance:

- Apparatus located in sleeping rooms or located in rooms remote from the fuel-burning appliance should be located relatively close to the breathing zone of the occupants

Where not to put the detector

The apparatus should not be installed:

- In an enclosed space (for example in a cupboard or behind a curtain)
- Where it can be obstructed (for example by furniture)
- Directly above a sink
- Next to a door or window
- Next to an extractor fan
- Next to an air vent or other similar ventilation openings
- In an area where the temperature may drop below -10°C or exceed 40°C
- Where dirt and dust may block the sensor
- In a damp or humid location (for example in a bathroom)

- Less than 1m/3 feet from any appliance
- Within 1m/3 feet of mobile phones

! **WARNING:** Prolonged exposure to temperatures outside those stated above will reduce battery and sensor life.

HOW TO INSTALL YOUR DETECTOR

i **NOTE:** This apparatus should be installed by a competent person who feels able to install it according to the instructions.

Firstly write the installation date on your detector in the area provided. We recommend that your detector is installed on the wall.

To mount on a wall or ceiling:

Please ensure that you use the screws provided, as they were chosen specifically for use with this product. Use template below for guidance on marking hole positions. Drill holes into the wall. Insert the plastic wall plugs. Screw in the screws. Ensure screws are protruding from the wall by 3mm to allow detector to slot onto screws.

To place on a shelf:

The base of the detector has been designed to allow it to stand freely on a shelf.

! **WARNING:** When placing on a shelf, please follow to the recommendations for positioning as described on pages 5 to 7.

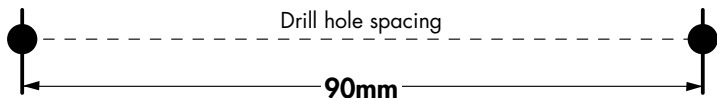

BATTERY INSTALLATION / REPLACEMENT

- a If the detector is already wall or ceiling mounted then unhook it from the mounting screws.
- b Remove the battery cover located on the back of the detector.
- c Replace the batteries with 2 x approved 1.5 volt AA size alkaline batteries (see page 16 for recommended batteries), making sure the batteries are the correct way round. Use of batteries other than those recommended by Zeta Alarm Systems may have a detrimental effect on the detector's operation. Replace the battery cover and return the detector to its original position.
- d Your advanced Zeta detector requires a short 'warm-up' period before it is fully operational.
If you have followed all of the above steps correctly, your unit will begin monitoring for CO in around 3 minutes. When the 3 minute warm-up period is complete, the Power LED will flash green once per minute to indicate that the alarm is receiving power from the batteries and is fully operational (if your detector chirps or enters alarm following the 3 minute warm-up period then please refer to page 12).

- e Test the sounder, batteries and circuitry by pressing and holding the Test/Reset button for 1 second. The sounder should sound as soon as the button is pressed, and the Alarm LED will illuminate red for a short time indicating that the sounder is working and the batteries are providing power to the unit. This test for the sounder, batteries and circuitry should be performed weekly.

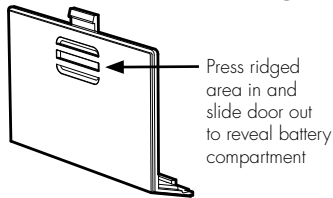
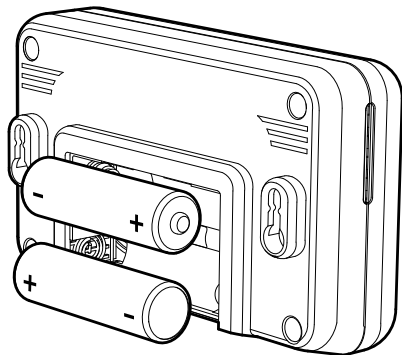

! **WARNING:** Prolonged exposure to the sounder in close proximity to your ears may damage your hearing.

Under normal operating conditions, the batteries should last for at least 12 months.

The detector will not protect against the risk of carbon monoxide poisoning when the batteries have drained.

! **WARNING:** Prolonged exposure to temperatures outside those stated above will reduce battery and sensor life.

OPERATING FEATURES

Your Zeta detector offers many features which set it apart from other CO detectors on the market today.

Test/Reset button feature

This button will:

- Test the sounder, batteries and circuitry
- Allow you to test the sensor by introducing a source of CO into the detector (see 'Testing The Sensor' below)
- Silence the loud 85dB sounder during an alarm (only possible when current CO level is less than 50ppm)

Testing the sounder, batteries and circuitry

Test the sounder, batteries and circuitry by pressing and holding the Test/Reset button for 1 second to confirm that the detector is operating properly. The sounder should sound as soon as the button is pressed, and the Alarm LED will illuminate red, indicating that the sounder is working and the batteries are providing power to the unit. This test for the sounder, batteries and circuitry should be performed weekly.

Testing the sensor

i **NOTE:** We suggest the use of an incense stick or cigarette as the inefficient

way in which these products burn means the smoke given off contains a detectable localised amount of carbon monoxide. Alternative sources of smoke, for example an extinguished candle or match, will not contain sufficient levels of carbon monoxide to obtain a response from the detector during this test. Please note your CO detector will not detect smoke.

If testing the sensor for the first time after installation, or replacing the batteries, make sure that the alarm has completed the initial 3 minute warm up period and the power LED is flashing green once every minute.

CAUTION: Sensor testing should only be performed by a responsible adult. This test should be performed annually.

NOTE: CO test kits may be used in order to avoid having to burn incense sticks or cigarettes. However we recommend that incense sticks are used as they are cheap and readily available.

- Read all steps thoroughly before attempting to test your the sensor

Step 1 If the detector is wall or ceiling mounted unhook the detector from the screws.

Step 2 Cover the sounder vents with one hand. Press and hold the Test/

Reset button down with your thumb/finger until the Power LED illuminates green and the sounder sounds for a second time (this should happen after around 5 seconds). Release the Test/Reset button. Upon releasing the Test/Reset button the Power LED will flash green once every second. This indicates that the sampling rate of the detector has increased and can be tested using a known source of CO.

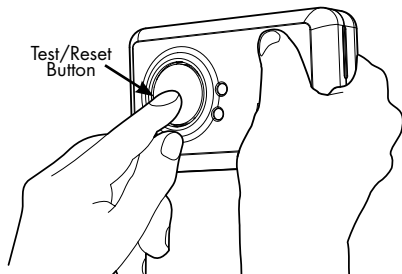

Step 3 Light an incense stick or cigarette using a match or lighter. If using an incense stick be sure to blow out the flame so that the incense stick is smouldering. Extinguish the lighter, or put out the match and place it into a dish of water.

Step 4 Turn the detector on its side so that the vents on the right

hand side of the detector are pointing downwards (see diagram opposite). Hold the burning incense stick or cigarette around 15cm (6 inches) below the detector, so that the smoke enters the vents on the side of the detector. An increase in the localised carbon monoxide level within the sensor to more than 50ppm will cause the sounder to sound for **one** cycle of four loud beeps and the Power LED to illuminate green for a short time. **This is the end of the test.** The Power LED will no longer flash green every second but will revert to flashing once every minute as the detector will go back to normal operating mode (It may take up to two minutes of exposure to the smoke for the localised level of carbon monoxide within the sensor to reach over 50ppm). Now move the source of CO away from the detector as the test is finished.

Step 5

After step 4, put out the incense stick or cigarette by placing it into a dish of water. Ensure that all flames have been extinguished.

i NOTE: If the localised carbon monoxide level within the sensor does not reach 50ppm during the test, the sensor test will stop automatically after 3 minutes.

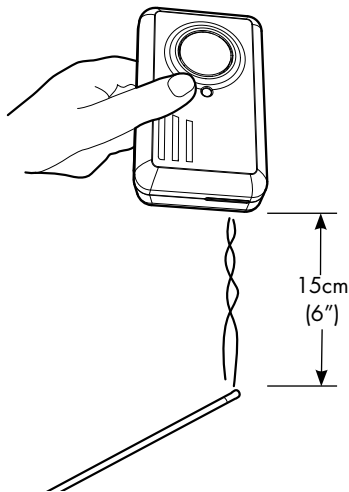

UNDERSTANDING THE PRODUCT'S INDICATORS

The higher the concentration of carbon monoxide detected by the detector, the quicker it will respond. When sufficient carbon monoxide is detected a loud audible signal (85 dB at 1m/3 feet) will be emitted and the Alarm LED will flash red once every second.

The Alarm will sound:

- Between 60 and 90 minutes when exposed to 50ppm of CO
- Between 10 and 40 minutes when exposed to 100ppm of CO
- Within 3 minutes when exposed to 300ppm or more

Fault / low battery signal:

The unit continuously checks the settings of its sensor and circuitry. If any of these settings are found to be incorrect or if the batteries become low then the detector will emit a **single audible chirp** once per minute for up to 30 days. **IMPORTANT:** This does NOT mean that the detector has detected carbon monoxide.

Replace batteries immediately. If the product continues to chirp despite having new batteries and the product is still within warranty then

contact technical support for advice. If the product is no longer in warranty **replace it immediately!**

Zeta Technical Support Line

9.00am–5.00pm, Monday–Friday.

Telephone: +44 (0) 1792 445 175

e-mail: support@zetaalarmsystems.com

MAINTAINING / TESTING YOUR DETECTOR

Maintenance

Your detector will alert you to potentially hazardous CO concentrations in your home when maintained properly. To maintain your Zeta detector in proper working order, and to ensure that the sensor will last for the lifetime of the product, it is recommended that you:

- Test the sounder, batteries and circuitry of your detector once per week by pressing and holding the Test/Reset button for 1 second (see page 9)
- Perform the Sensor Test annually (see page 9)
- Keep the detector free of dust by gently vacuuming the case with a soft brush attachment when required.

To prevent the possibility of contaminating the sensor in your detector and thus affecting its reliability:

- Never use cleaning solutions on your detector. Simply wipe with a slightly damp cloth
- Do not paint the detector
- Do not spray aerosols on or near the detector
- Do not use any solvent based products near the detector
- Move the detector to a safe location and

store in a plastic bag before painting, wall papering, or performing any other activities using substances that emit strong fumes. Remember to remove it from the bag and return the detector to its original location when these activities are finished

Failure of any test should be reported to the technical support line (see page 19 for contact details).

Do not attempt to repair your CO detector. Do not remove any screws or open the main casing of your detector. Any attempt to do so may cause malfunction and will invalidate the warranty.

WHAT TO DO IN THE EVENT OF AN ALARM

! **WARNING:** A loud alarm is a warning that unusually high and potentially lethal levels of carbon monoxide are present. Never ignore this alarm, further exposure can be fatal. Immediately check residents for symptoms of carbon monoxide poisoning, and contact the proper authorities to resolve all CO problems. **NEVER IGNORE ANY ALARM.**

Please carefully review this owner's manual to ensure that you know what actions to take in the event of an alarm.

What to do during an alarm

- Keep calm and open the doors and windows to ventilate the property
- Stop using all fuel burning appliances and ensure, if possible, that they are turned off
- Evacuate the property leaving the doors and windows open
- Ring your gas or other fuel supplier on their emergency number; keep the number in a prominent place

Write your fuel supplier's emergency number here (see opposite for more useful numbers):

- Do not re-enter the property until the alarm has stopped. When exposed to fresh air it can take up to 10 minutes for the sensor to clear and the alarm to stop depending on the level of carbon monoxide detected
- Get medical help immediately for anyone suffering the effects of carbon monoxide poisoning (headache, nausea), and advise that carbon monoxide poisoning is suspected
- Do not use the appliances again until they have been checked by an expert. In the case of gas appliances the engineer must be registered

UK USEFUL NUMBERS

National Gas Emergency Service **0800 111 999** (24 Hours)

Gas Safe register **0800 408 5500**

Solid Fuel Association **0845 601 4406**
Advisory service for domestic and solid fuel
appliances

HETAS **0845 223 3033**
Trade association for solid fuel engineers

OFTEC **0845 658 5080**
Trade association for Oil Fired Appliance
engineers

NACS **01785 811 732**
National Association of Chimney Sweeps

IPHE **01708 472 791**
Institute of Plumbing and Heating Engineers

TECHNICAL INFORMATION

Detector Specifications:	Model ZD-CO-9B
Sensor Type:	Electrochemical
Sensor Life:	7 Years
Alarm Sound Level:	85dB at 1m/3 feet
Recommended Batteries:	Size AA Alkaline - Duracell LR6, Energizer LR6, Gold Peak 1.5A
Battery Life:	Exceeds 1 year under normal operating conditions, replaceable
Temperature Range:	-10°C (14°F) to 40°C (104°F)
Operating Humidity Range:	30 - 90% RH
Weight (inc. batteries):	125 grams (4.4oz)
Certified to:	BS EN 50291 : 2001

! **WARNING:** Prolonged exposure to temperatures and humidity outside those stated above will reduce battery and sensor life.

This Zeta carbon monoxide detector is designed to continuously monitor for CO. Its response times meet the requirements of the European standard BS EN 50291:2001.

The alarm will sound:

- Between 60 and 90 minutes when exposed to 50ppm of CO
- Between 10 and 40 minutes when exposed to 100ppm of CO
- Within 3 minutes when exposed to CO levels of 300ppm or more

! **WARNING:** APPARATUS CONFORMING TO THIS STANDARD MAY NOT PROTECT PEOPLE WHO ARE AT SPECIAL RISK FROM CARBON MONOXIDE EXPOSURE BY REASON OF AGE, PREGNANCY OR MEDICAL CONDITION. IF IN DOUBT, CONSULT YOUR DOCTOR.

A CARBON MONOXIDE DETECTOR IS NOT A SUBSTITUTE FOR A SMOKE ALARM OR A COMBUSTIBLE GAS DETECTOR.

THE ZD-CO-9B HAS AN OPERATIONAL LIFETIME OF 7 YEARS FROM THE DATE IT IS INSTALLED AND ACTIVATED. RECORD THE DATE OF INSTALLATION ON THE STICKER PROVIDED AND REPLACE UNIT AFTER 7 YEARS OF OPERATION.

DISPOSAL

Waste electrical products should not be disposed of with regular household waste. Please recycle where facilities exist. Check with your local authority, retailer or the Zeta Technical Support Line (see page 19 for contact details) for recycling/disposal advice as regional variations apply.

The batteries should be removed before disposal of the detector. Both the batteries and the detector should be disposed of in line with current regulations.

You can also return your carbon monoxide detector to us for disposal. For return address see the section on Returns. Please include a note confirming the product is being returned for disposal.

! **WARNING:** DO NOT ATTEMPT TO OPEN - DO NOT BURN



7 YEAR WARRANTY

Warranty coverage

Zeta Alarm Systems warrants to the original purchaser that its enclosed sealed carbon monoxide detector be free from defects in materials and workmanship under normal residential use and service for a period of 7 (seven) years from the date of purchase.

Provided it is returned with postage prepaid and proof of purchase, Zeta Alarm Systems hereby warrants that during the 7 (seven) year period commencing from the date of purchase Zeta Alarm Systems, at its discretion, agrees to replace the unit free of charge. The warranty on any replacement Zeta ZD-CO-9B Carbon Monoxide Poisonous Gas Alarm will last for the remainder of the period of the original warranty in respect of the detector originally purchased – that is from the date of original purchase and not from the date of receipt of the replacement product. Zeta Alarm Systems reserves the right to offer an alternative product similar to that being replaced if the original model is no longer available or in stock. This warranty applies to the original retail purchaser from the date of original retail purchase and is not transferable. **Proof of purchase is required.**

Warranty disclaimers

This warranty does not cover damage resulting from accident, misuse, disassembly, abuse or

lack of reasonable care of the product, or applications not in accordance with the user manual. It does not cover events and conditions outside of Zeta Alarms Systems' control, such as Acts of God (fire, severe weather etc). It does not apply to retail stores, service centres or any distributors or agents. Zeta Alarm Systems will not recognise any changes to this warranty by third parties. Zeta Alarm Systems shall not be liable for any incidental or consequential damages caused by the breach of any expressed or implied warranty. Except to the extent prohibited by applicable law, any implied warranty of merchantability or fitness for a particular purpose is limited in duration to 7 years.

This warranty does not affect your statutory rights. Except for death or personal injury, Zeta Alarm Systems shall not be liable for any loss of use, damage, cost or expense relating to this product or for any indirect, or consequential loss, damages or costs incurred by you or any other user of this product.

The warranty does not cover the batteries which are considered user-replaceable parts.

RETURNS

Should you encounter a problem with your alarm, we recommend that you contact the Zeta Technical Support Line in the first instance for advice on **+44 (0) 1792 455 175** (9.00am–5.00pm, Monday–Friday), as we may be able to remedy the problem quickly over the phone (this is to prevent unnecessary returns that take a longer time to process). Alternatively e-mail:

support@zetaalarmssystems.com

If there is a fault that we are unable to resolve then our technical support team member will issue you with a returns authority number so that your product can be returned for testing.

To return your Zeta ZD-CO-9B under warranty, send it suitably packed and with the batteries disconnected with postage prepaid; a note indicating the returns authority number and describing the reason for return, with proof of purchase to:

**Zeta Alarm Systems
Detection House
72-78 Morfa Road
Swansea
SA1 2EN**

PRODUCT RANGE

Zeta Alarm Systems provide an extensive range of Fire Alarm Systems, Gas Detection & Emergency Systems. For more details visit **www.zetaalarmssystems.com**

NOTES

Technical Support Line
+44 (0) 1792 455 175

Email
support@zetaalarmsystems.com

Web
www.zetaalarmsystems.com



BS EN 50291:2001
KM 551504

Zeta Alarm Systems
Detection House
72-78 Morfa Road
Swansea, SA1 2EN

ZD-CO-9B
GN0501/R2